

BALDOR® • RELIANCE 

Product Information Packet

EWCM3710T

7.5HP,1770RPM,3PH,60HZ,213TCZ,3738M,TEFC

Part Detail							
Revision:	C	Status:	PRD/A	Change #:		Proprietary:	No
Type:	AC	Elec. Spec:	37WGR872	CD Diagram:	CD0005	Mfg Plant:	
Mech. Spec:	37N046	Layout:	37LYN046	Poles:	04	Created Date:	12-07-2015
Base:	RG	Eff. Date:	09-06-2019	Leads:	9#14		

Specs			
Catalog Number:	EWCM3710T	Insulation Class:	F
Enclosure:	TEFC	Inverter Code:	Inverter Ready
Frame:	213TCZ	KVA Code:	J
Frame Material:	Steel	Lifting Lugs:	Standard Lifting Lugs
Output @ Frequency:	7.500 HP @ 60 HZ	Locked Bearing Indicator:	Locked Bearing
Synchronous Speed @ Frequency:	1800 RPM @ 60 HZ	Motor Lead Quantity/Wire Size:	9 @ 14 AWG
Voltage @ Frequency:	460.0 V @ 60 HZ	Motor Lead Exit:	Ko Box
	230.0 V @ 60 HZ	Motor Lead Termination:	Flying Leads
XP Class and Group:	None	Motor Type:	3738M
XP Division:	Not Applicable	Mounting Arrangement:	F1
Agency Approvals:	UR	Power Factor:	80
	CSA EEV	Product Family:	General Purpose
	CSA	Pulley End Bearing Type:	Ball
Auxillary Box:	No Auxillary Box	Pulley Face Code:	C-Face
Auxillary Box Lead Termination:	None	Pulley Shaft Indicator:	Tapped & Key
Base Indicator:	Rigid	Rodent Screen:	None
Bearing Grease Type:	Polyrex EM (-20F +300F)	RoHS Status:	ROHS COMPLIANT
Blower:	None	Shaft Extension Location:	Pulley End

Current @ Voltage:	19.000 A @ 230.0 V	Shaft Ground Indicator:	No Shaft Grounding
	20.000 A @ 208.0 V	Shaft Rotation:	Reversible
	9.500 A @ 460.0 V	Shaft Slinger Indicator:	No Slinger
Design Code:	A	Speed Code:	Single Speed
Drip Cover:	No Drip Cover	Motor Standards:	NEMA
Duty Rating:	CONT	Starting Method:	Direct on line
Electrically Isolated Bearing:	Not Electrically Isolated	Thermal Device - Bearing:	None
Feedback Device:	NO FEEDBACK	Thermal Device - Winding:	None
Front Face Code:	Standard	Vibration Sensor Indicator:	No Vibration Sensor
Front Shaft Indicator:	None	Winding Thermal 1:	None
Heater Indicator:	No Heater	Winding Thermal 2:	None

Nameplate NP3441L										
CAT.NO.	EWCM3710T									
SPEC.	37N046R872G1									
HP	7.5									
VOLTS	230/460									
AMP	19/9.5									
RPM	1770									
FRAME	213TCZ				HZ	60		PH	3	
SER.F.	1.15		CODE	J		DES	A		CL	F
NEMA-NOM-EFF	91.7		PF	80						
RATING	40C AMB-CONT									
CC	010A				USABLE AT 208V			20		
DE	6309				ODE	6206				
ENCL	TEFC		SN							
VPWM INVERTER READY										
CT6-60H(10:1)VT3-60H(20:1)										

Parts List		
Part Number	Description	Quantity
SA311549	SA 37N046R872G1	1.000 EA
RA298976	RA 37N046R872G1	1.000 EA
37FN3002C01	EXFN, PLASTIC, 6.00 OD, 1.155 ID	1.000 EA
HW3200A01	3/8-16X3/4 I-BLT WELDED F/S	1.000 EA
37CB3006	37 CB CASTING W/1.38 LEAD HOLE @ 6:00	1.000 EA
37GS1000SP	GASKET, CONDUIT BOX STD., .06 THICK LEXI	1.000 EA
51XW2520A12	.25-20 X .75, TAPTITE II, HEX WSHR SLTD	2.000 EA
11XW1032G06	10-32 X .38, TAPTITE II, HEX WSHR SLTD U	1.000 EA
37EP3101A29	FR ENDPLATE, FOR ROUTING PURPOSES	1.000 EA
HW4500A01	1641B(ALEMITE)400 UNIV, GREASE FITT	1.000 EA
HW4500A17	317400 ALEMITE GREASE RELIEF	1.000 EA
HW5100A06	W2420-025 WVY WSHR (WB)	1.000 EA
37EP3401T10	EP PU ENCL 309 BRG W/GRSR & RELIEF, META	1.000 EA
HW4500A01	1641B(ALEMITE)400 UNIV, GREASE FITT	1.000 EA
HW4500A17	317400 ALEMITE GREASE RELIEF	1.000 EA
10XN2520A36	1/4-20X 2 1/4 HEX HD X	4.000 EA
XY3118A12	5/16-18 HEX NUT DIRECTIONAL SERRATION	4.000 EA
51XB1214A20	12-14X1.25 HXWSSLD SERTYB	1.000 EA
07FH4007SP	PRIMED	1.000 EA
51XW1032A06	10-32 X .38, TAPTITE II, HEX WSHR SLTD S	3.000 EA
37CB4516	LIPPED LID FOR 37 FRAME NEC KOBX	1.000 EA
37GS1008	37 GS FOR CB LID - LEXIDE	1.000 EA
51XW0832A07	8-32 X .44, TAPTITE II, HEX WSHR SLTD SE	4.000 EA
HA2009A02	SLINGER MODEL 37 PUMP MOTORS-2.75 DIA. A	1.000 EA

Parts List (continued)		
Part Number	Description	Quantity
HW2501D13	KEY, 3/16 SQ X 1.375	1.000 EA
HA7000A01	KEY RETAINER 7/8" DIA SHAFT	1.000 EA
80XN1032A06	10-32 X 3/8 SET SC HEX SOCK	1.000 EA
85XU0407S04	4X1/4 U DRIVE PIN STAINLESS	2.000 EA
LB1115N	LABEL,LIFTING DEVICE (ON ROLLS)	1.000 EA
MJ1000A02	GREASE, MOBIL POLYREX EM - 124047	0.050 LB
MG1000Y03	MUNSELL 2.53Y 6.70/ 4.60, GLOSS 20,	0.028 GA
HA3104A17	5/16-18X13.250 T-BLT/OHIO	4.000 EA
LC0005E01	CONN.DIA./WARNING LABEL (LC0005/LB1119N)	1.000 EA
NP3441L	ALUM SUPER-E VPWM INVERTER READY UL	1.000 EA
37PA1039	PALLET PACK GRP, PRINT PK1026A06	1.000 EA
MN416A01	TAG-INSTAL-MAINT no wire (1200/bx) 3/19	1.000 EA

AC Induction Motor Performance Data

Record # 54275 - Typical performance - not guaranteed values

Winding: 37WGR872-R001	Type: 3738M	Enclosure: TEFC
-------------------------------	--------------------	------------------------

Nameplate Data				460 V, 60 Hz: High Voltage Connection	
Rated Output (HP)	7.5			Full Load Torque	22.2 LB-FT
Volts	230/460			Start Configuration	direct on line
Full Load Amps	19/9.5			Breakdown Torque	70.9 LB-FT
R.P.M.	1770			Pull-up Torque	32.6 LB-FT
Hz	60	Phase	3	Locked-rotor Torque	43 LB-FT
NEMA Design Code	A	KVA Code	J	Starting Current	70.9 A
Service Factor (S.F.)	1.15			No-load Current	4.31 A
NEMA Nom. Eff.	91.7	Power Factor	80	Line-line Res. @ 25°C	1.41 Ω
Rating - Duty	40C AMB-CONT			Temp. Rise @ Rated Load	63°C
S.F. Amps				Temp. Rise @ S.F. Load	77°C
				Locked-rotor Power Factor	37.2
				Rotor inertia	0.934 LB-FT ²

Load Characteristics 460 V, 60 Hz, 7.5 HP

% of Rated Load	25	50	75	100	125	150	S.F.
Power Factor	42	64	75	80	83	84	82
Efficiency	87.1	91.6	92	92	91.1	89.8	91.5
Speed	1793	1786	1778	1770	1760	1750	1764
Line amperes	4.83	6.02	7.6	9.5	11.6	13.9	10.8

Performance Graph at 460V, 60Hz, 7.5HP Typical performance - Not guaranteed values

ABB Motors and Mechanical Inc.

WINDING # 37WGR872

Typical performance - not guaranteed values.

7.5 HP 3 PH 60 HZ 1770 RPM 460 V 3738M

TORQUES(LB-FT): PO=70.9 PU=32.6 LR=43 LRA=70.9

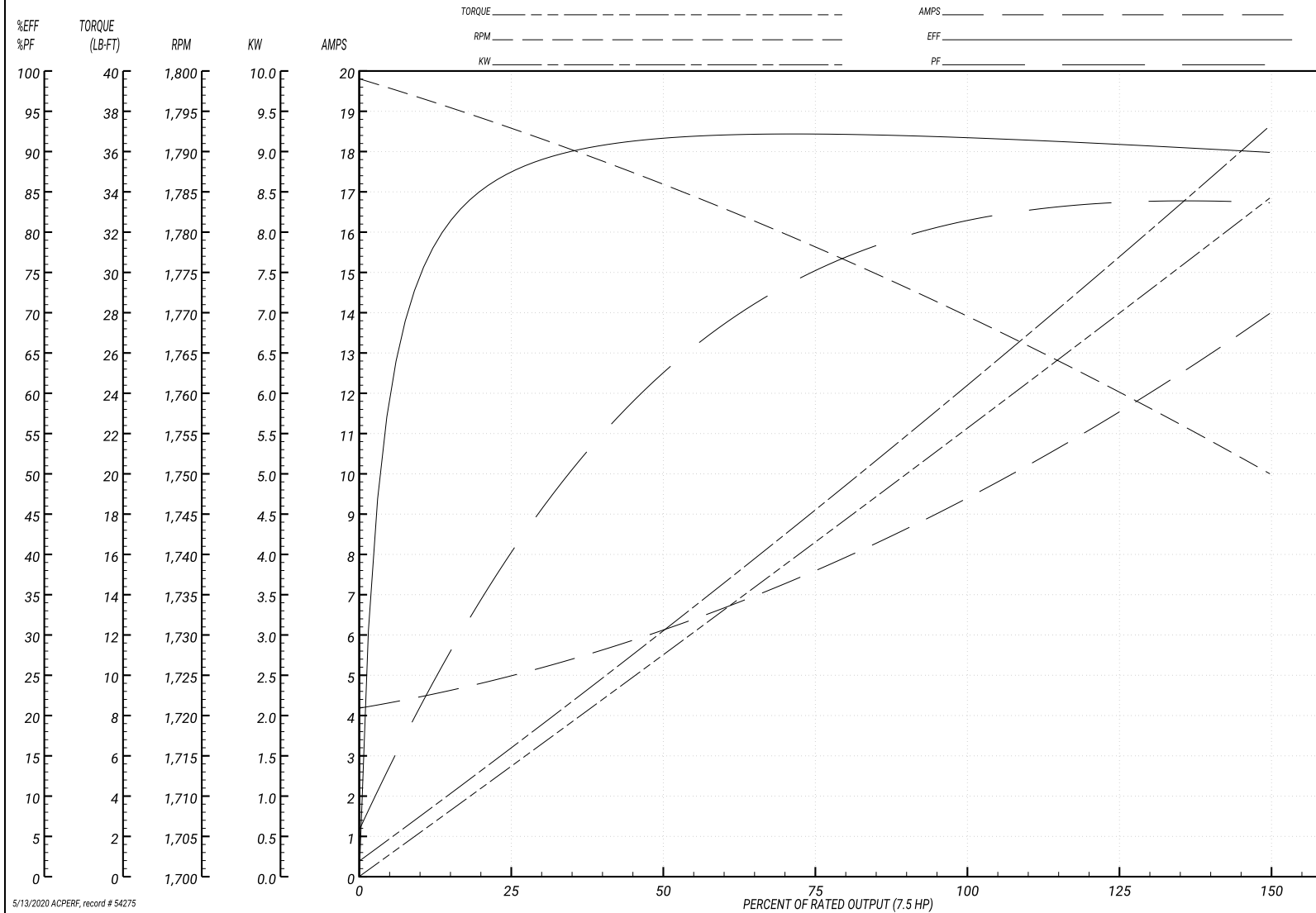

5/13/2020 ACPERF, record # 54275

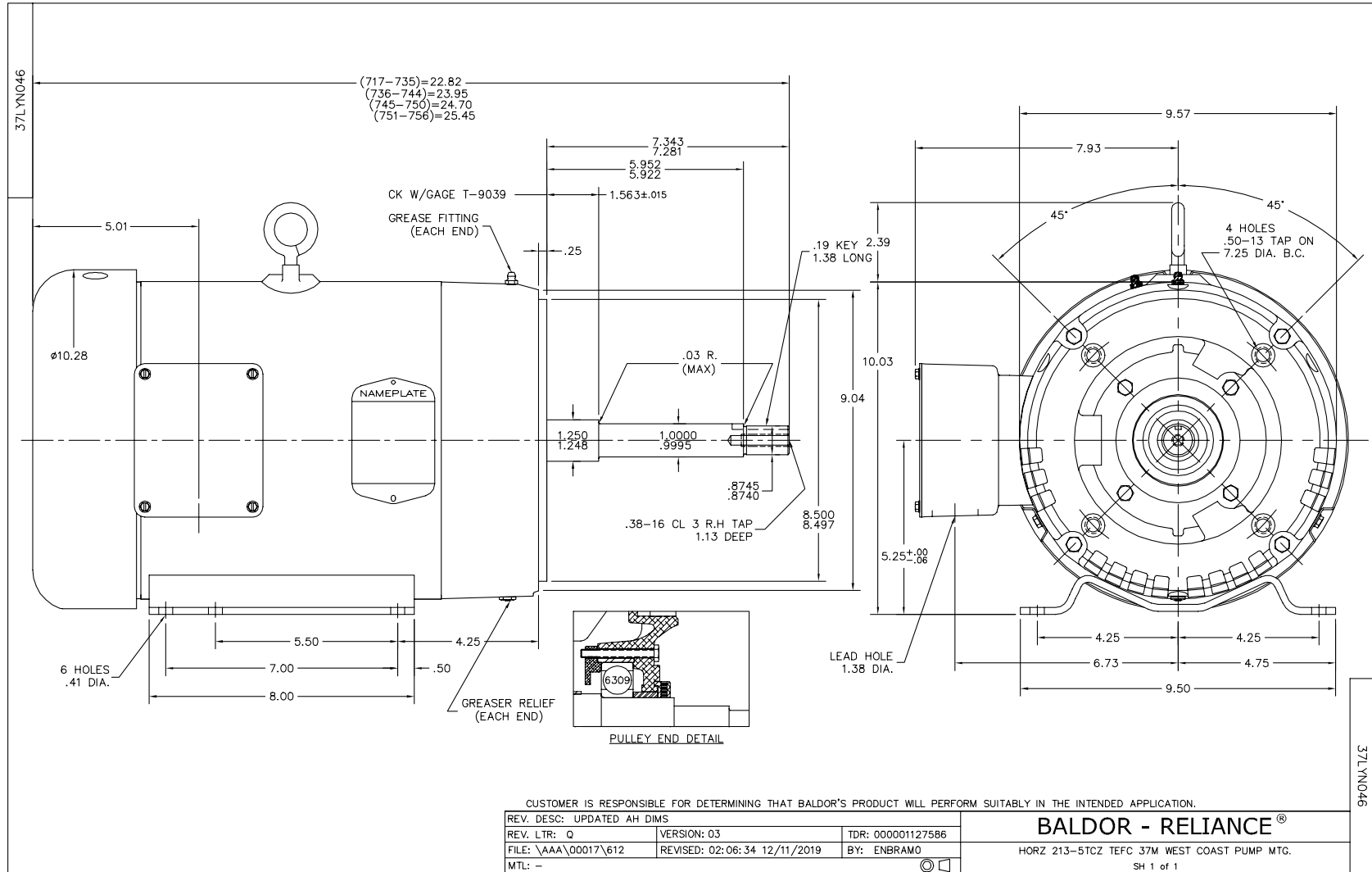

CD0005



LOW VOLTAGE
(2Y)



LINE

HIGH VOLTAGE
(1Y)

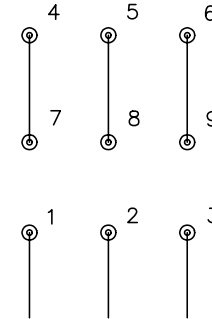

LINE

NOTES:

1. INTERCHANGE ANY TWO LINE LEADS TO REVERSE ROTATION.
2. OPTIONAL THERMOSTATS ARE PROVIDED WHEN SPECIFIED.
3. ACTUAL NUMBER OF INTERNAL PARALLEL CIRCUITS MAY BE A MULTIPLE OF THOSE SHOWN ABOVE.
4. LEAD COLORS ARE OPTIONAL. LEADS MUST ALWAYS BE NUMBERED AS SHOWN.

REV. DESC: REVISE TO SHOW OPTIONAL COLORS			
REV. LTR: E	BY: JLP	REVISED: 01/19/99 10:15	TDR: 0171435
90000		FILE: AAA00005140	MDL: -
		MTL: -	

BALDOR ELECTRIC Co.

3PH, DV, 9 LEADS

CD0005